

客选	高度	PCS/盘
	H=0.4mm	10000

客选	按力规格 A
	160 ⁺⁴⁰ ₋₂₀ gf
	260 ⁺⁴⁰ ₋₂₀ gf
	300 ⁺⁴⁰ ₋₂₀ gf

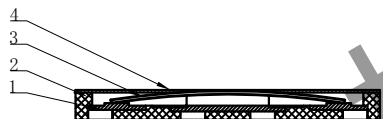
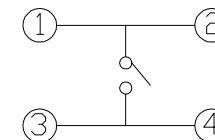
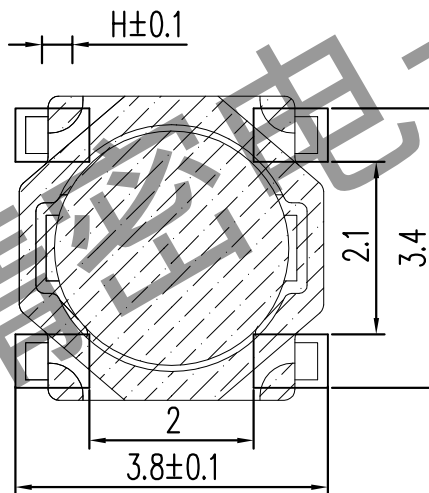
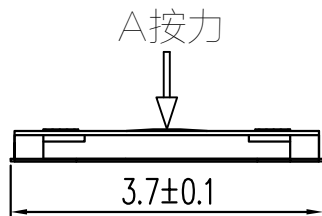

PCB板焊盘尺寸

电路图

NO.	NAME	MATERIAL	FINISHING
1	TERMINAL	phosphorous bronze	Silver plating
2	CASE	LCP	White
3	CONTACT	SUS301	Silver plating
4	Waterproof membrane	PI	Yellow

SPECIFICATIONS	
Operating temperature rangs	-30° to +85°
Rating	DC 12V 50mA Max.
Lifetime	50000 Cycles min
Contact Resistance	100mΩ Max
Dielectric strength	250V AC for 1min.
Travel	0.15±0.1mm
Solder temperature	255±5°

东莞市上楷精密电子有限公司
Dongguan Shangkai Precision Electronics Co., LTD

PART NAME		SWITCH		DRAWING		DWG.No.		SBICL	
PART NO.		TD-1832UR		CHECK		REV.		A1	
UNIT : mm	TOLERANCE	UP TO 5	±0.2	ANGLE	APPROVAL	DATE			
	OTHERWISE	ABOVE 5 ~ 30	±0.3			PAGE		1 OF 1	
		ABOVE 30	±0.5	0°±3'	SCALE	2:1			